

VSO® LowPro Miniature Proportional Valve

Low Profile Proportional Valve



The VSO® LowPro is a miniature proportional valve that controls the flow rate of inert gases at pressures up to 100 PSIG (6.9 bar). Typical flow rates up to 57 SLPM with a typical power of 1 Watt at room temperature. At just 16 mm wide by 14 mm tall, the valve can be populated into the smallest portable device improving performance, size and weight. With orifice sizes ranging from 0.030" (0.76) up to 0.080" (2.03 mm) and a weight of 12 g, the VSO® LowPro can perform the function of valves three times its size without sacrificing the power. Mounting only requires a simple, machined manifold.

Markets

- Portable Oxygen Concentrators
- Ventilators
- Patient Monitors

Applications

- Pressure Control
- Volumetric Flow Control
- Pulse Dose Control

Features

- Very low power required of typically 1 Watt enables portable capability and low power control increasing battery life or reducing the size of your power supply or battery
- Low profile design simplifies mounting and eliminates cartridge configurations that require complex & expensive machining
- Delivers consistent performance on every valve
- Reach, RoHS, ISO 15001, IP65, and CE compliant



Product Specifications

Physical Properties

Valve Type:
2-Way Normally Closed
Media:
Air, Oxygen or any non-reactive, non-condensing gases
Operating Environment:
32 to 131°F (0 to 55°C)
Storage Temperature:
-40 to 158°F (-40 to 70°C)
Length:
0.80 in (20 mm)
Width:
0.63 in (16 mm)
Height:
0.55 in (14 mm)
Porting:
Face Seal to Manifold with integrated FKM seal
Weight:
0.42 oz (12 g)

Electrical

Power:
1.0 Watt Typical 2.0 Watt Maximum
Voltage:
5, 12 and 24 VDC See Table 2
Electrical Termination:
4.5" (114 mm) Wire leads [26 AWG] with Molex 50-57-9402 connector

Wetted Materials

Body & Cover:
Aluminum 430 Stainless Steel
Armature & Spring:
Carbon Steel (Nickel Plated) Stainless Steel
Coil:
Urethane Polyvinyl Butyral
All Others:
FKM, Epoxy
Regulatory:
Compliant with RoHS directive (2002/95/EC), REACH EC 1907/2006, ISO 15001, IP65(IEC/EN 60529), and CE

Performance Characteristics

Leak Rate: *
Internal: 0.5 SCCM of Air with a differential pressure of 100 psid (6.9 bar) External: 0.2 SCCM of Air with a differential pressure of 100 psid (6.9 bar) <i>* The leakage shall not exceed the above values.</i>
Operating Pressure: See Table 1
0 - 100 psi (6.9 bar)
Vacuum:
0-27 in Hg (0-686 mm Hg)
Proof Pressure:
300 psi (20.7 bar)
Orifice Sizes:
0.030 in (0.76 mm) 0.040 in (1.02 mm) 0.050 in (1.27 mm) 0.080 in (2.03 mm)
Hysteresis:
10% of full scale current (Typical) 15% of full scale current (Maximum)
Recommended Filtration:
40 µm (not supplied)
Response time:
10 ms Typical
Reliability:
100 Million Cycles 0.96 Reliability Factor 99% Confidence Interval



VSO® LowPro Low Profile Proportional Valve

Typical Flow Curve

Miniature Proportional Valves

All Models
Typical Air Flow with 12 VDC Coil @ 25 psid (1.7 bar)

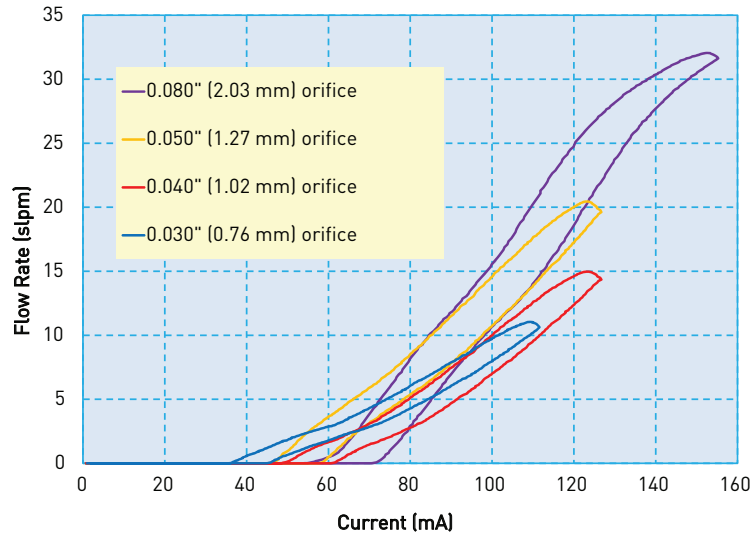

Pressure vs Flow Curve

The curve below shows the maximum output flow for each orifice size as a function of inlet pressure up to the maximum rated pressure for the valve.

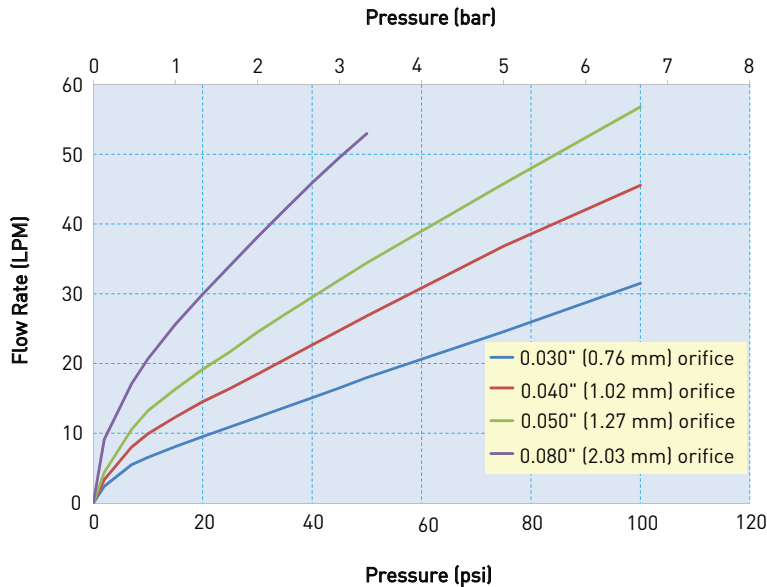

Pressure and Flow Capabilities

Table 1

Model No.	Orifice Diameter	Cv at Maximum Pressure	Maximum Inlet Pressure	Maximum Differential Pressure
3	0.030" (0.76 mm)	0.015	100 psi (6.9 bar)	100 psig (6.9 bar)
4	0.040" (1.02 mm)	0.022	100 psi (6.9 bar)	100 psig (6.9 bar)
5	0.050" (1.27 mm)	0.027	100 psi (6.9 bar)	100 psig (6.9 bar)
8	0.080" (2.03 mm)	0.045	100 psi (6.9 bar)	50 psig (3.4 bar)



VSO[®] LowPro Low Profile Proportional Valve

VSO[®] LowPro Sizing Charts

Model 3 - 0.030" (0.76mm) Orifice
Pressure (bar)

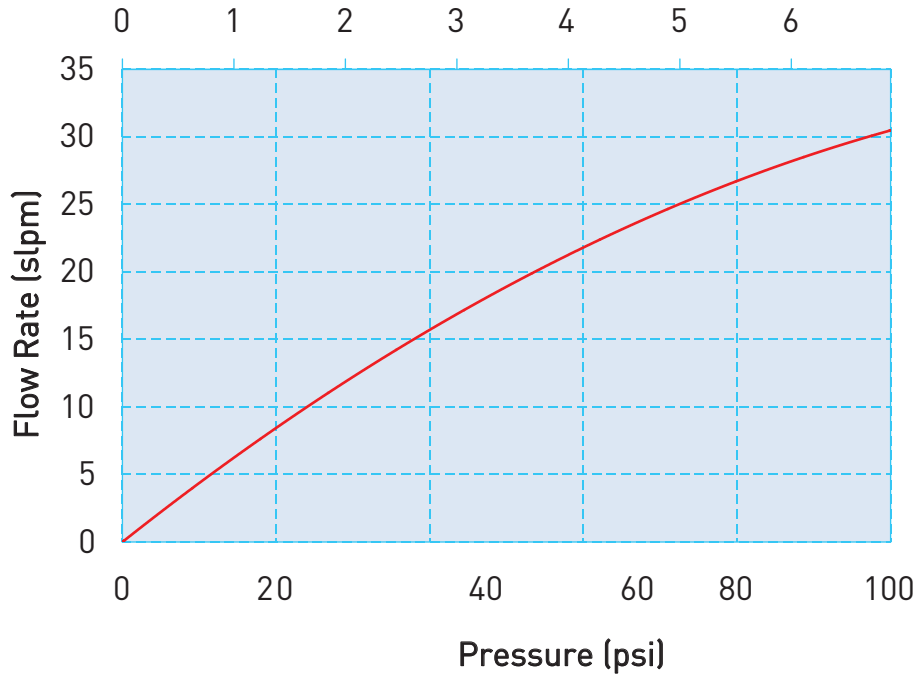

Model 4 - 0.040" (1.02 mm) Orifice
Pressure (bar)

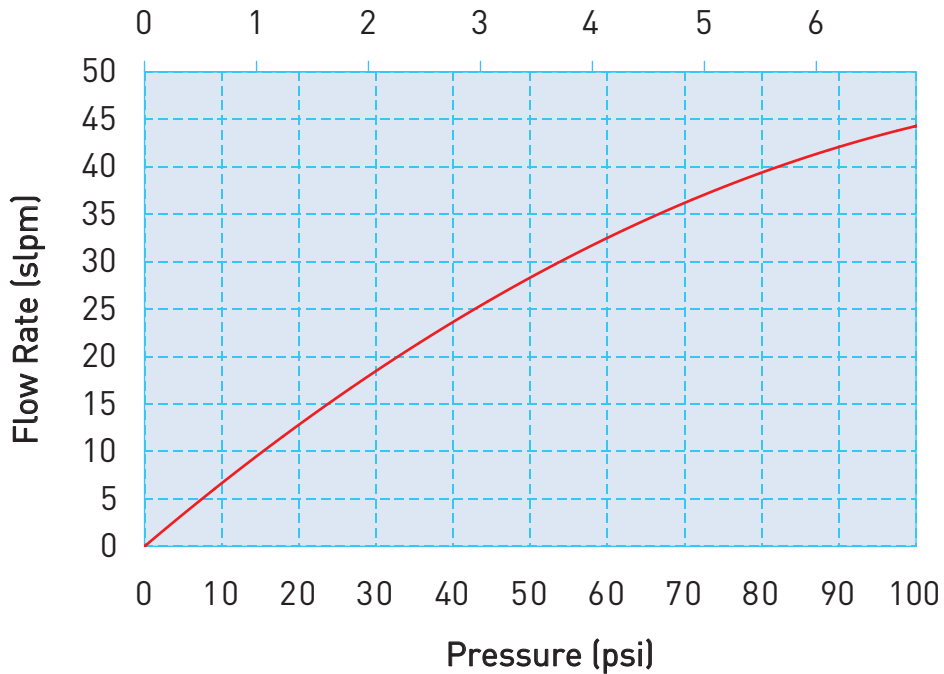

VSO[®] LowPro Low Profile Proportional Valve
VSO[®] LowPro Sizing Charts

Model 5 - 0.050" (1.27 mm) Orifice

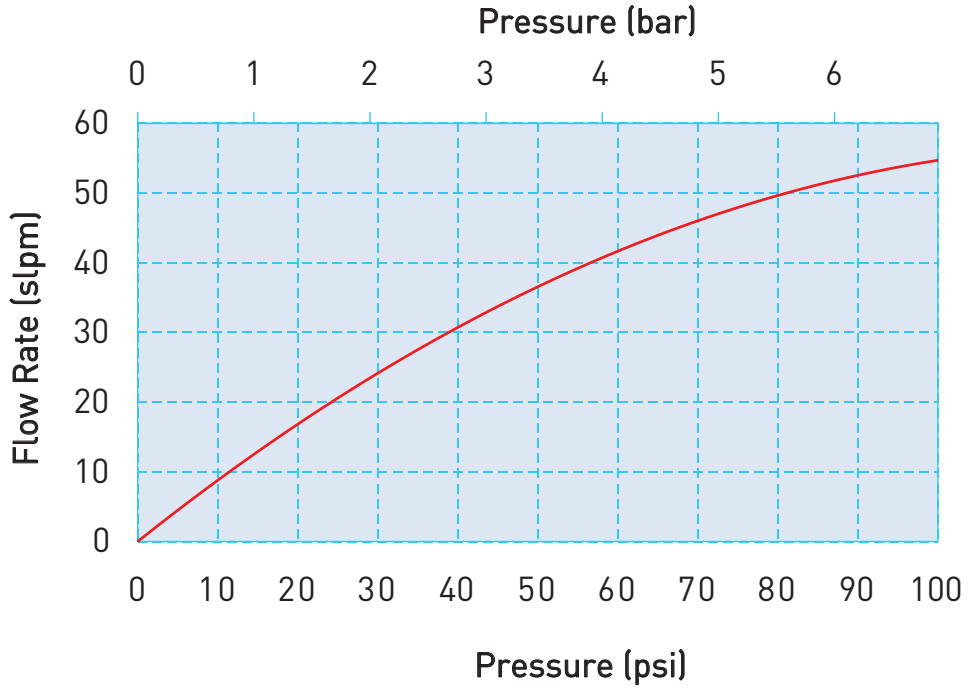

Model 8 - 0.080" (2.03 mm) Orifice

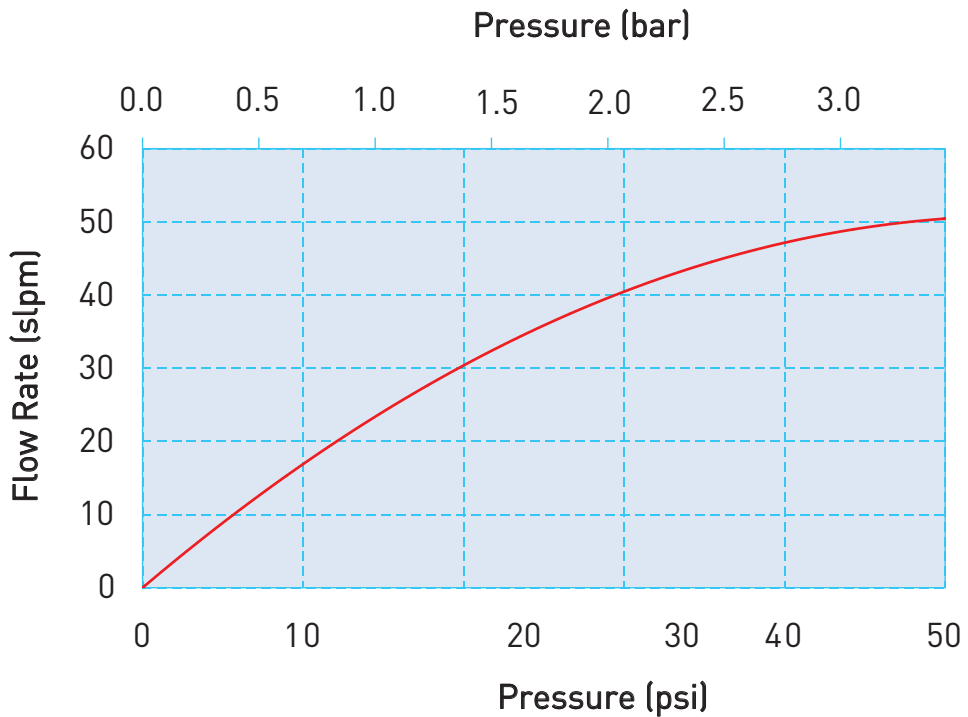

VSO[®] LowPro Low Profile Proportional Valve Pneumatic Interface

VSO[®] LowPro Manifold Mount



Mechanical Integration Dimensions

VSO[®] LowPro Basic Valve Dimensions

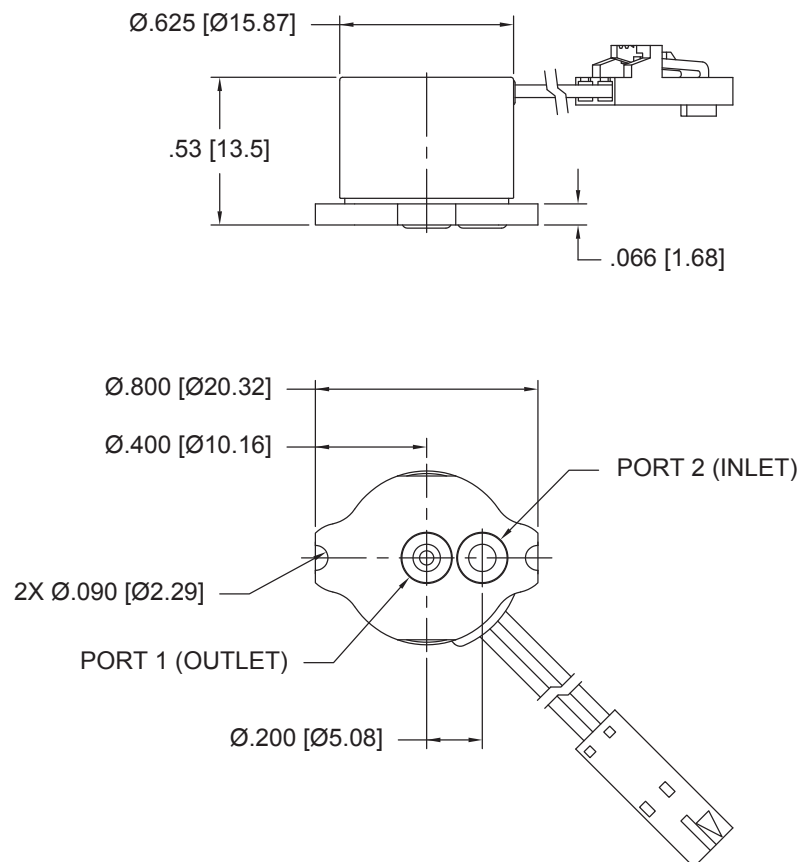

UNITS
IN [MM]



VSO® LowPro Low Profile Proportional Valve

Electrical Interface

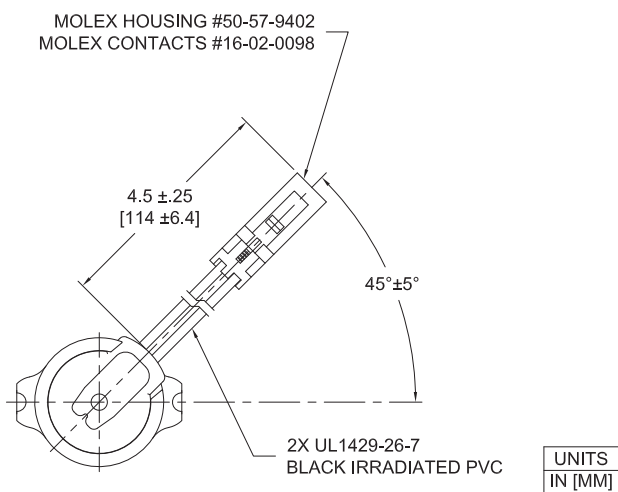

Electrical Requirements

Table 2

Rated Voltage	Nominal Coil Resistance at 20°C	Control Current at Maximum Flow		
		Model 3	Model 4 & 5	Model 8
5 VDC	10 Ω	275 mA	311 mA	385 mA
12 VDC	61 Ω	112 mA	127 mA	156 mA
24 VDC	179 Ω	65 mA	75 mA	92 mA

Installation and Use

Typical Valve Set-up

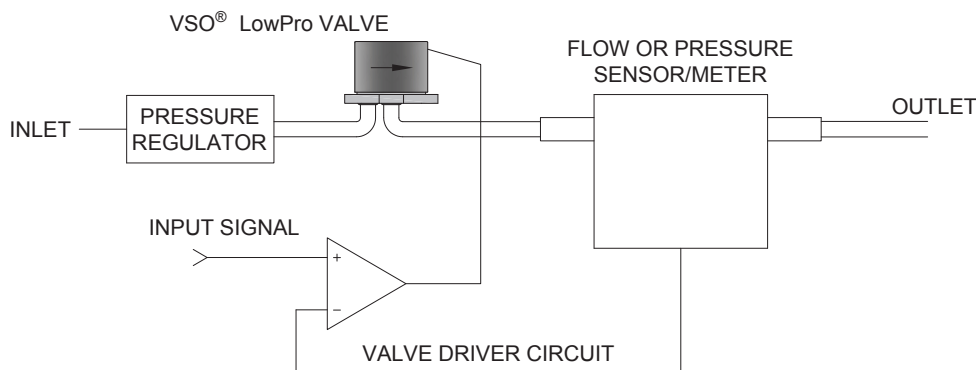

Valve Electrical Control

Basic Control:

The VSO® LowPro valve can be controlled by either voltage or current; however, it is highly recommended that current control be employed to ensure the most repeatable valve flow performance.

PWM Control:

For PWM control, the signal applied to the valve should have a frequency of 10 kHz or greater. Optimum frequency will be application dependent.

VSO® LowPro Low Profile Proportional Valve Installation and Use

Suggested VSO® LowPro Current Driver Schematic

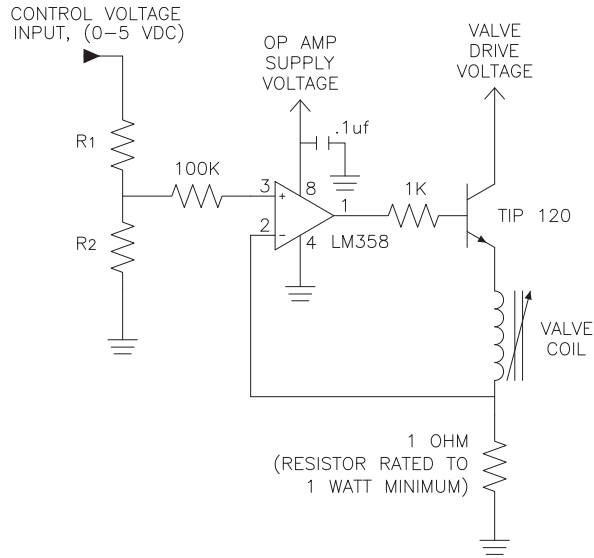

This simple current driver circuit draws only 1 mA at the input control (0-5VDC) and provides control for any VSO® LowPro valve configuration regardless of valve voltage or resistance.

Table 3 (below) describes the recommended R1 and R2 resistor values based upon the full shut-off current.

Table 3: Selectable Resistor Values for a Low Current (1 mA) LM358-Based Current Driver (All Models)

Maximum Solenoid Voltage (VDC)	Circuit Supply Voltage (VDC)	Nominal Coil Resistance @ 20 °C (Ohms)	Maximum Output Current from Circuit (mA)	R1 (Ohms)	R2 (Ohms)
6.0	8.0	10.1	396	4910	422
13.0	15.0	61.3	160	3320	110
22.0	24.0	178.5	94	2100	40.2

VSO[®] LowPro Low Profile Proportional Valve

Installation and Use

Manifold & Dimensions & Design

Not shipped with valves.

Parker Precision Fluidics recommends 24 in-oz (17 N-cm) of torque for the screws.

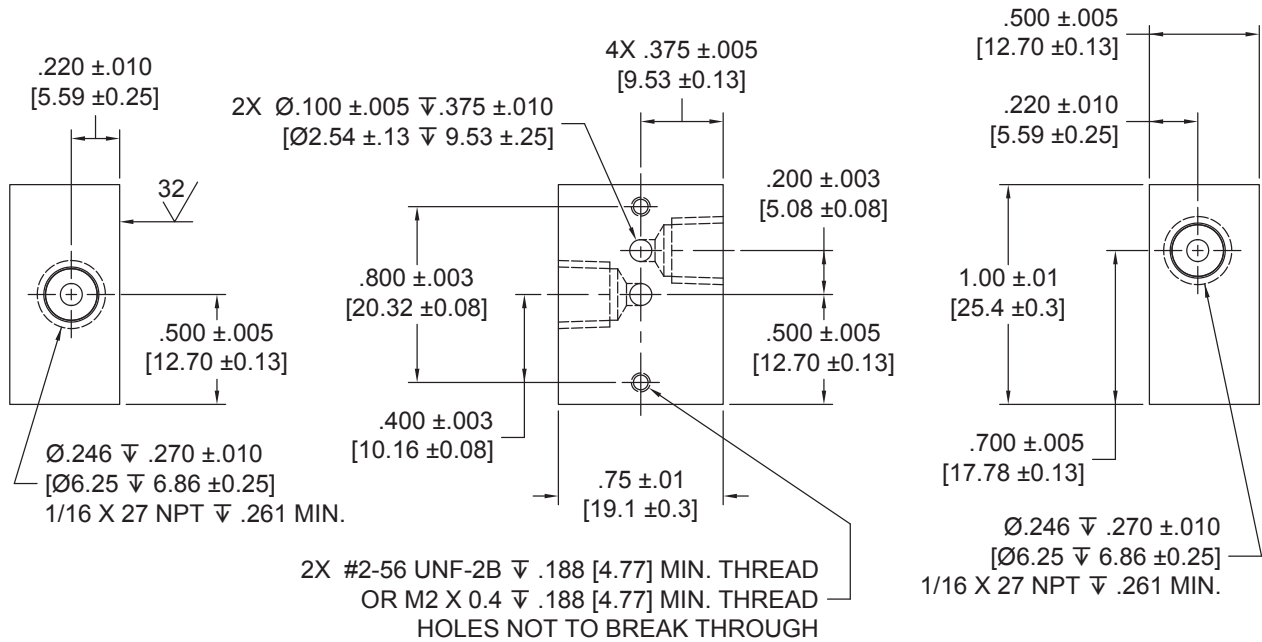

UNITS
IN [MM]

VSO[®] LowPro Low Profile Proportional Valve Typical Flow Diagram

Oxygen Concentrator Application

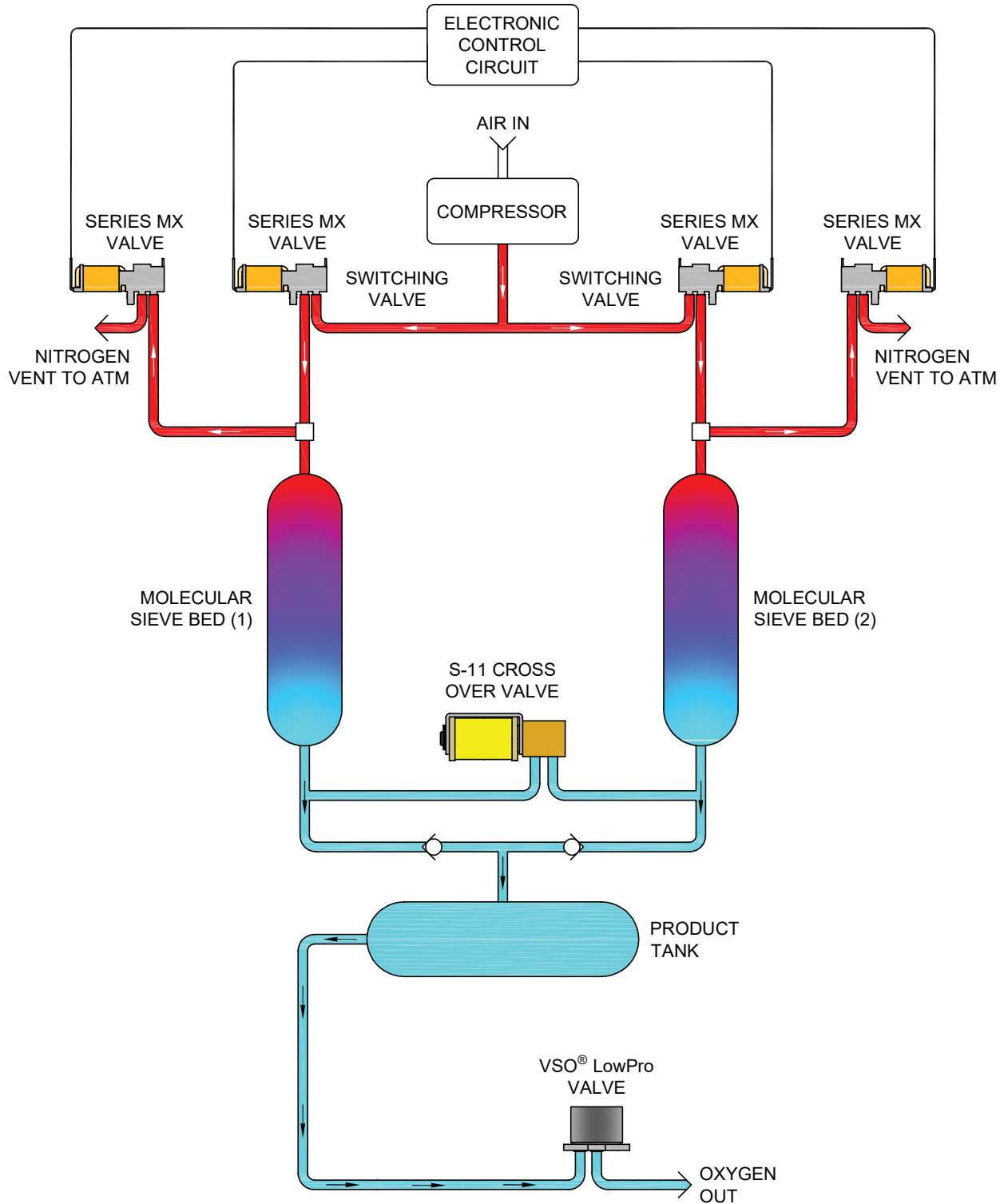

VSO® LowPro Low Profile Proportional Valve

Accessories

12.5" Adapter Wire Leads
290-006061-003



Screw #2-56 x 3/16" Socket Head Cap Screw
191-000112-404

(see valve mounting recommendations above)



Single Station Manifold
890-009042-001



Manifold O-Ring (FKM)
190-007059-001
(supplied with valve)



Ordering Information

Sample Part ID	93	5	-	30	0	05	0	-	00	0
Description	Series	Isolation	-	Model Number	Elastomer	Voltage	Body Material	-	Pneumatic Interface	Electrical Interface
Options	93	5: Non-Isolated	-	30: 100 psi / 0.030" (0.76 mm) 40: 100 psi / 0.040" (1.02 mm) 50: 100 psi / 0.050" (1.27 mm) 80: 50 psi / 0.080" (2.03 mm)	0: FKM Seals	05: 5 VDC 12: 12 VDC 24: 24 VDC	0: Aluminum	-	00: Manifold Mount	0: Wire Leads w/ connector

Accessories	
290-006061-003: 12.5 in (318 mm) Adapter Wire Leads	**Not supplied with the valve.
890-009042-001: Manifold, Single Station, 1/8 in NPT	**Not supplied with the valve.
190-007059-001: Manifold O-Ring (FKM)	**Supplied with the valve.
191-000112-404 Screw#2-56 x 2/16 in Socket Head Cap Screw	**Not supplied with the valve. See Valve Mounting Recommendations above

NOTE: In order to provide the best possible solution for your application, please provide the following requirements when contacting Applications Engineering:

- Media, Inlet & Outlet Pressures
- Minimum Required Flow Rate
- System Supply Voltage
- Media & Ambient Temperature Range



Please click on the Order On-line button to configure your VSO® LowPro Proportional Valve (or go to www.parker.com/precisionfluidics/VSOLowProMiniatureProportionalValve). For more detailed information, visit us on the Web, or call and refer to VSO® LowPro Performance Spec. 790-002490-001.

Parker Hannifin Precision Fluidics Division reserves the right to make changes. Drawings are for reference only.

For more information call +1 603 595 1500 or email ppfinfo@parker.com
Visit www.parker.com/precisionfluidics

